

| REVISION RECORD | | | | |
|-----------------|-----|-------------|------|------|
| REV | ECO | DESCRIPTION | DRFT | CHKD |
| | | | | |

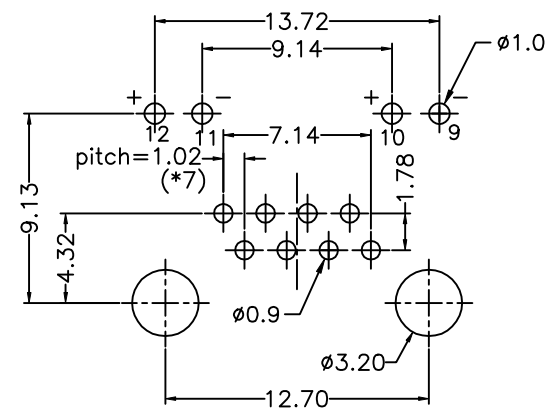
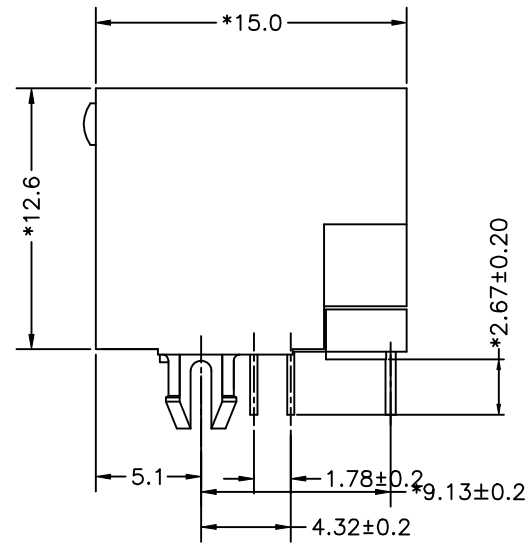
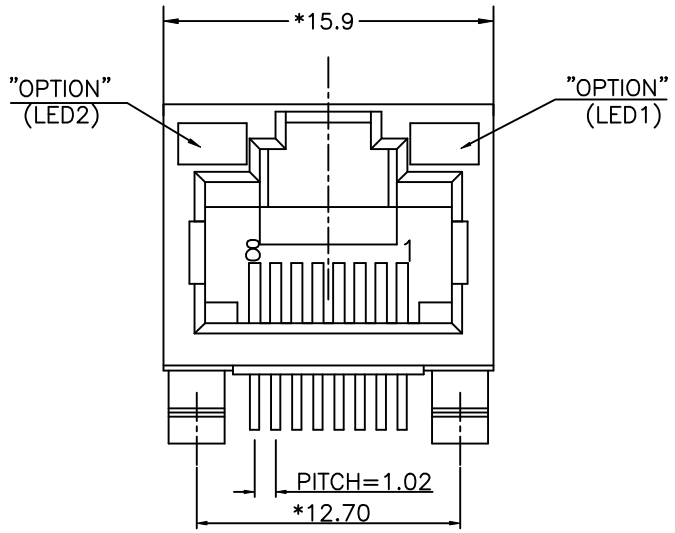

PC Board Layout
PCB t = 1.60mm

NOTES:
ELECTRICAL:

- VOLTAGE RATING : 125 VAC RMS.
- CURRENT RATING : 1.5 AMP.
- CONTACT RESISTANCE : 30 MILLIOHMS MAX.
- INSULATION RESISTANCE: 1000 MEGOHMS MIN @ 500 VDC.
- DIELECTRIC STRENGTH : 1000 VAC RMS 60Hz, 1MIN.
- LED RATINGS: FORWARD VOLTAGE: 2.2 VOLTS TYPICAL.
REVERSE VOLTAGE: 5 VOLTS MAXIMUM.
- OPERATING: 750 CYCLES MIN.

PART NUMBER: E 5J 8 8 - X 0 L J D X-L

- LED1:GREEN ,LED2:YELLOW
- LED1:GREEN ,LED2:GREEN
- LED1:YELLOW ,LED2:GREEN
- LED1:G+Y ,LED2:G+Y
- LED1:RED ,LED2:GREEN
- LED1:YELLOW ,LED2:YELLOW

PLATING: 1-3u", 4-30u"
2-6u", 5-50u"
3-15u"

JD-W/O LOGO FR52 STAMPED PIN

MECHANICAL:

- HOUSING MATERIAL : FR52 UL94V-0. COLOR-BLACK.
- INSERT MATERIAL : FR52 UL94V-0. COLOR-BLACK.
- LENS MATERIAL : FR52 UL94V-0. COLOR-CLEAR.
- BACK PLATE MATERIAL : FR52 UL94V-0. COLOR-BLACK.
- LED SIZE : 3.2*2.0*4.0*P=2.29mm OR 3.1*1.8*7.0*P=2.54mm.
- CONTACT MATERIAL : PHOSPHOR BRONZE 0.35mm THICKNESS
- PLATING : GOLD PLATING OVER NICKEL.
- PCB RETENTION PRE-SOLDER : 1 LB MIN.
- PCB RETENTION POST-SOLDER: 10 LBS MIN.

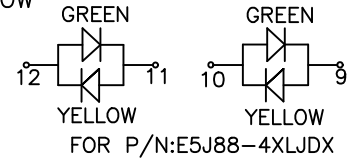

FOR P/N:E5J88-4XLJDX

ENVIRONMENTAL:

- STORAGE : -40°C TO +85°C.
 - OPERATION: 0°C TO 70°C.
 - WAVE SOLDERING TEMPERATURE: 255~265° (5~10 SECONDS)
- MATES WITH MODULAR PLUG CONFORMING TO
FCC PART 68, SUBPART F.
CUL FILE NO. E163191

| | | | | | |
|----------------|----------------------------|--------------|----------------|-------------------------------|------|
| DETACHED LISTS | MM (INCH) | DFTO PETERS | DATE 03/25/05 | FULL RISE ELECTRONIC CO., LTD | |
| | TOLERANCES EXCEPT AS NOTED | CHKD-MAE | DATE 2005/3/25 | | |
| | | MFO | DATE | | |
| | | APPVLLUSHENG | DATE 2005/3/26 | | |
| | MM | | | TITLE | |
| | .0 ± 0.20 | ± | | LED JACK | |
| | .00 ± 0.15 | ± | | DRAWING NO. GE5J3197-LA | |
| | .000 ± 0.075 | ± | | /PART NO. SEE NOTE | |
| | ANGLES ± | | QTY : | SIZE | REV |
| | | | | A3 | 0 |
| | THIRD ANGLE PROJECTION | | FINISH : | DO NOT SCALE DRAWING | |
| | | | SCALE : 4:1 | SHEET X | OF Y |